

Upgrading a SAS[®] 9.1 or 9.1.2 System to a SAS[®] 9.1.3 System

This document explains how to upgrade from a 9.1 or 9.1.2 SAS[®] Intelligence Platform system to a 9.1.3 system. The procedures described here assume that you are not installing any new products and that your initial installation was a Project or planned installation.

If your system is on **any platform other than z/OS** (see note below), you have two options for upgrading:

1. Replace your 9.1 or 9.1.2 SAS Intelligence Platform software with your 9.1.3 SAS Intelligence Platform software. We call this option “upgrading in place.” Use this option to minimize the amount of time spent in upgrading.
2. Alternatively, you can temporarily maintain separate 9.1[.2] and 9.1.3 SAS Intelligence Platform systems. This enables you to test the 9.1.3 SAS Intelligence Platform software before taking your 9.1 or 9.1.2 SAS Intelligence Platform system out of production. Choosing this option will take longer but will permit you to be more certain that everything is working correctly before you change your production environment to the new system.

Both options are explained in the procedures that follow. In either case, you will need a 9.1.3 plan.xml file.

Note: Upgrade procedures are different for z/OS systems. If you are using the z/OS platform, see the section "Upgrading a SAS 9.1 or 9.1.2 z/OS System to a SAS 9.1.3 System".

Table of Contents

Overview of Upgrading a SAS 9.1 or 9.1.2 System to a SAS 9.1.3 System	3
Assumptions.....	3
Before You Begin the Upgrade	3
Your Two Options for Upgrading.....	4
Upgrading in Place	4
Upgrading After Testing in a Test Environment	5
Building a Test System.....	5
Updating Your Production System	7
Upgrading Each Machine	7
Metadata Server Host	7
Stop the Metadata Server.....	8
Copy Files from the Original Configuration Directory.....	8
Start the Metadata Server.....	8
Upgrade Your Metadata	8
Set Up the SAS/CONNECT® Spawner (Windows only).....	8
Reestablish Existing Schedule Flows	9
Server Machine, No Metadata Server	9
Reapply Customizations from the Original Configuration Directory	9
Set Up the SAS/CONNECT Spawner (Windows only)	9
Start Your Servers	9
Middle-Tier Machine.....	9
Reapply Customizations from the Original Configuration Directory	10
Prepare to Reapply Customizations to Web Applications.....	10
Upgrade User and Group Definitions (9.1 to 9.1.3 only)	10
Define the SAS Foundation Services in the Metadata.....	10
Update the SAS Web Infrastructure Kit Metadata	11
Copy Custom Portlets to the Installation Directory.....	11
Migrate Your WebDAV Data to a 9.1.3 Test System (SAS Information Delivery Portal).....	12
Migrate Your WebDAV Data to a 9.1.3 Test System (SAS Web Report Studio)	13
Migrate Your WebDAV Data in the 9.1.3 Production System (SAS Information Delivery Portal).....	13
Migrate Your WebDAV Data in the 9.1.3 Production System (SAS Web Report Studio).....	15
Start the SAS Services Application.....	16
Deploy Your Web Applications	17
Upgrading a SAS 9.1 or 9.1.2 z/OS System to a SAS 9.1.3 System	17
Installing and Configuring the SAS 9.1.3 Software.....	17
Replacing Your Production System.....	20

Overview of Upgrading a SAS 9.1 or 9.1.2 System to a SAS 9.1.3 System

This document explains how to upgrade from a 9.1 or 9.1.2 business intelligence system to a 9.1.3 system.

- For all platforms except z/OS, see “Your Two Options for Upgrading” for pointers to the upgrade instructions.
- For instructions on upgrading a z/OS system, see “Upgrading a SAS 9.1 or 9.1.2 z/OS System to a SAS 9.1.3 System”.

The following subsections discuss:

- the assumptions that SAS is making about your current installation and the software that you plan to install.
- the tasks that you must perform prior to following the steps in this document.
- your options for upgrading your machines that are not on a z/OS system.

Assumptions

SAS assumes the following about your system:

- Your initial installation was a Project installation. (A *Project installation* is a planned installation, similar to an Advanced or a Personal installation of the 9.1.3 software.)
- You are not installing any new products. You are simply upgrading your existing environment.

Before You Begin the Upgrade

Before you actually begin the upgrade, perform the following tasks:

1. Plan a time to do the upgrade.
2. If you will be performing an advanced installation of the 9.1.3 software, set up a new project directory. You will need a 9.1.3 Software Installation Data file(s) and a 9.1.3 planning file. The planning file must have the same name as your 9.1.2 planning file and must contain the same content.

A recommended best practice is to generate your 9.1.3 plan by taking the following steps in the planning tool:

- a. Locate your 9.1.2 plan in the planning tool, and edit that plan in order to change its name.
- b. Make a copy of the 9.1.2 plan.
- c. Give the copy of the 9.1.2 plan the name that was originally assigned to your 9.1.2 plan, and set its **SAS Release** to 9.1.3.
- d. Save the 9.1.3 plan.

Note: It is also a good practice to save a copy of old **plan.xml** files. Rename each old plan with a name that is similar to **plan_912_10APR04.xml**.

3. Back up your current configuration.

Your Two Options for Upgrading

You have two options for upgrading your system:

- You can simply replace your 9.1 or 9.1.2 software with your 9.1.3 software, or...
- You can temporarily maintain separate 9.1[.2] and 9.1.3 systems so that you can test the 9.1.3 software before taking your 9.1 or 9.1.2 system out of production.

For information about these options, see the following sections:

- “Upgrading in Place”.
- “Upgrading After Testing in a Test Environment”.

Upgrading in Place

The upgrade-in-place procedure is designed to allow you to minimize the amount of time involved in upgrading. The procedure is illustrated in the following figure.

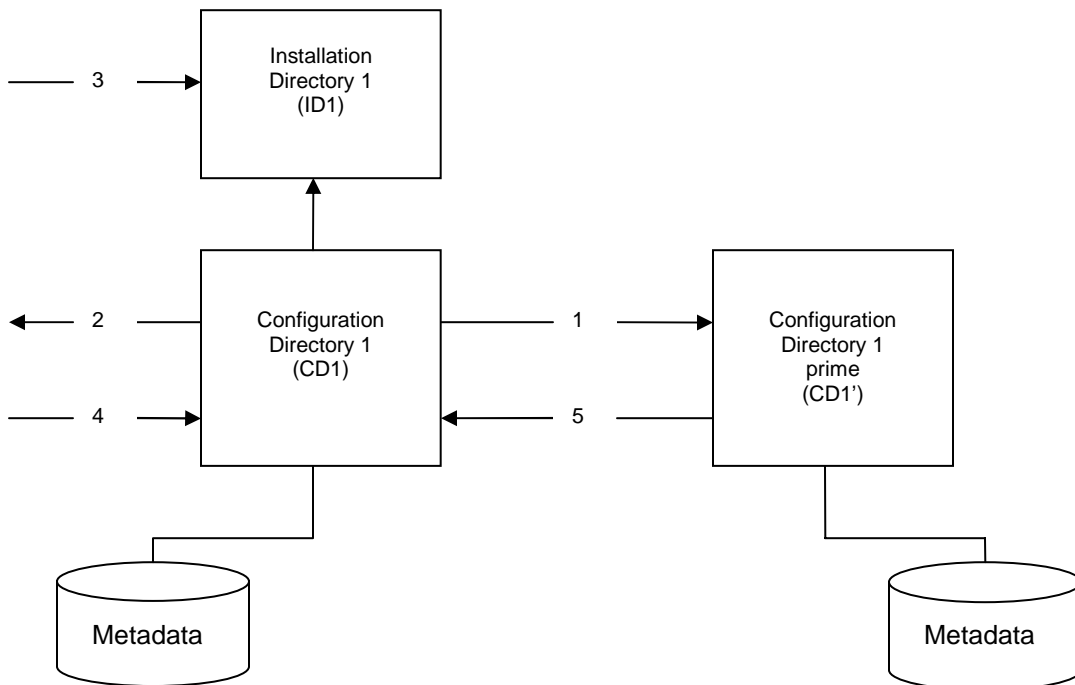

For each machine in your system, stop any servers that are running on that machine, and then perform the following tasks. (The following numbered steps correspond to the numbers in the previous figure.) Start with your metadata-server machine. Then proceed to other server-tier machines, middle-tier machines, and client machines, in that order.

1. Copy your 9.1[.2] configuration directory (CD1) to a backup location (CD1'). Also, back up any custom portlets that are located in the directory `SAS-install-di\Web\Portal2.0.1\DeployedPortlets`.

2. Uninstall the 9.1[.2] configuration by running the appropriate uninstall program.
 - On Windows systems, run the executable *path-to-config-dir\UninstallerData\Uninstall SAS Configuration Wizard.exe*.
 - On UNIX systems, run...*path-to-config-dir\UninstallerData\Uninstall_SAS_Configuration_Wizard*. If necessary, also delete the configuration directory from the file system.
3. Install the 9.1.3 software—including the 9.1.3 clients—in ID1. There is no need to uninstall the 9.1[.2] software first.

For third-party software, such as the BEA WebLogic Server, make sure that you have the supported version of the product installed. You can find information about the supported version of each such product at <http://support.sas.com/thirdpartysupport>.

4. Run the SAS Configuration Wizard, and specify the original configuration directory (CD1) as your configuration directory.

CAUTION: Do not follow the HTML instructions that are generated by the SAS Configuration Wizard. These generated instructions are meant for a new configuration. Follow the instructions that are referred to in Step 5 instead. (When the SAS Configuration Wizard finishes running, it starts SAS[®] Management Console, and you are asked whether you want to create a new metadata repository. You do not need to create this repository; you will later copy your original metadata repository from CD1' to CD1.)

5. Execute the manual upgrade instructions that are documented in “Upgrading Each Machine”. Choose the correct set of instructions for the machine that you are currently working on.

Upgrading After Testing in a Test Environment

If you want to maintain both 9.1[.2] and 9.1.3 business intelligence systems for a testing period, before you make the 9.1.3 system your production system, see the following sections.

Building a Test System

Build a test system by following the steps that are shown in the following figure.

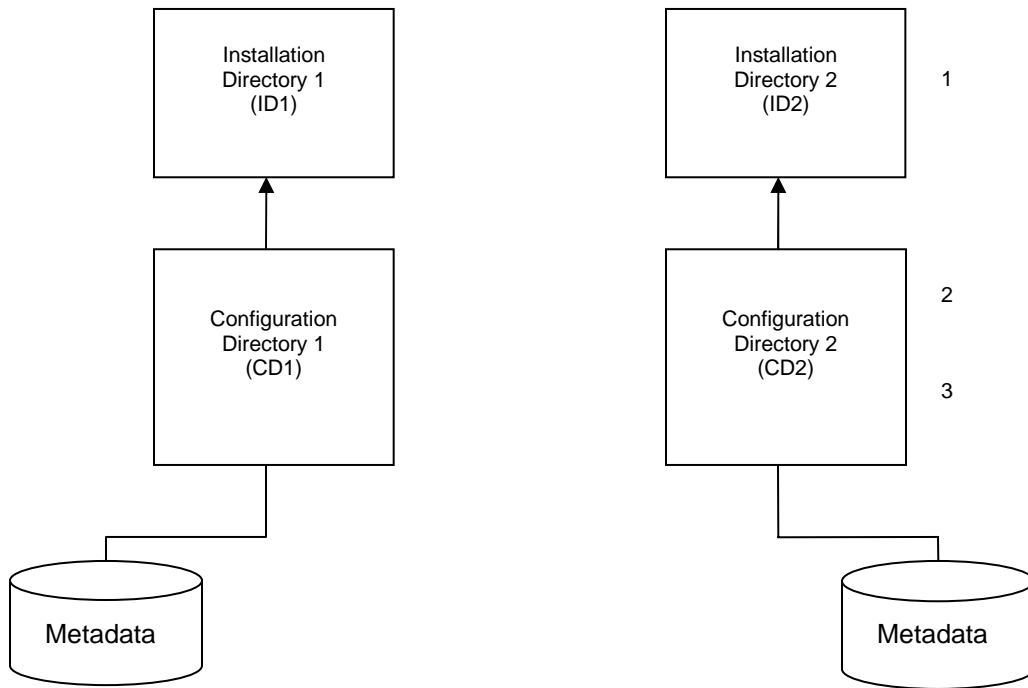

For each machine in your configuration, perform the following steps (the following numbered steps correspond to the numbers in the previous figure):

Note: Start with your metadata-server machine. Then proceed to other server-tier machines, the middle-tier machine, and client machines, in that order.)

1. Install the 9.1.3 software on a different machine of the same type (or possibly on the same machine) in ID2.

For each Windows machine in your installation, you must install the SAS 9.1.3 software on a different Windows machine. For each UNIX machine, SAS recommends that you install the SAS 9.1.3 software on a different UNIX machine. However, it is possible to install the SAS 9.1.3 software on the same UNIX machine as SAS 9.1[.2] software.

CAUTION: If you choose to install SAS 9.1[.2] and SAS 9.1.3 software on the same UNIX system, be aware that when you installed your SAS 9.1[.2] software, a preference file was created that will prevent you from installing the SAS 9.1.3 software in a new location.

Therefore, before you can install SAS 9.1.3 software on a host where SAS 9.1[.2] software is installed, you must rename this preferences file. The **vpd.properties** file is located either in the **sas** user's home directory (Solaris and HP-UX IPF) or in **/usr/lib/objrepos** (AIX). Rename this file **vpd.properties91** or **vpd.properties912**.

Note: Renaming this file will prevent you from uninstalling your SAS 9.1[.2] software later. To uninstall that software, perform the following steps:

- a. Rename the SAS 9.1.3 **vpd.properties** file to **vpd.properties913**.
- b. Change the name of the SAS 9.1[.2] properties file back to **vpd.properties**.
- c. Uninstall your SAS 9.1[.2] software.
- d. Delete the SAS 9.1[.2] properties file.
- e. Change the name of the SAS 9.1.3 properties file back to **vpd.properties**.

Note: For third-party software, such as the BEA WebLogic Server, make sure that you install the supported version of the product. You can find information about the supported version of each such product at <http://support.sas.com/thirdpartysupport>.

2. Run the SAS Configuration Wizard to produce CD2. If you are installing a 9.1.3 system side by side with a 9.1.[.2] system, be sure to use different port numbers than the port numbers that you used to configure your 9.1.[.2] system.

CAUTION: Do not follow the HTML instructions that were generated by the SAS Configuration Wizard. These generated instructions are meant for a new configuration. Follow the instructions in Step 3 instead. (When the SAS Configuration Wizard finishes running, it starts SAS Management Console, and you are asked whether you want to create a new metadata repository. You do not need to create this repository; you will later copy your original metadata repository from CD1 to CD2.)

3. Execute the manual upgrade instructions that are documented in the section “Upgrading Each Machine”. Choose the correct set of instructions for the machine that you are currently working on.

Then test the entire system.

Updating Your Production System

After you are satisfied with your testing, you will need to update your production system. To do this, you follow the same steps that you follow to upgrade a system in place—see “Upgrading in Place”—with the following caveat. Depending on where you installed your new software in building your test system, you might not need to reinstall the 9.1.3 software. Instead, you might be able to use the existing installation from your test system. Your hardware deployment and standard operating procedures will dictate whether this is feasible. For example, you might be able to use UNIX NFS mount points to accomplish this.

CAUTION: Do not copy your test system’s configuration directory and metadata repositories. In the process of creating that system, you made several edits to that directory that might or might not be appropriate for your production system.

Upgrading Each Machine

Perform the steps in each of the following sections whose title describes the machine on which you are working:

- If your metadata server is configured on the machine, follow the directions in “Metadata Server Host”.
- If the machine hosts SAS servers—but not the metadata server—follow the directions in “Server Machine, No Metadata Server”.
- If your middle-tier software, for example your J2EE application server, is installed on the machine, follow the directions in “Middle-Tier Machine”.

You might need to perform the steps in two sections. For instance, if you have installed the SAS Intelligence Platform on a single machine, you should consult the first and third sections. In such a case, follow the directions in the first relevant section before performing those in the second relevant section.

Metadata Server Host

On the machine where the SAS Metadata Server is configured, perform the steps in the following sections:

1. “Stop the Metadata Server”.
2. “Copy Files from the Original Configuration Directory”.
3. “Start the Metadata Server”.
4. “Upgrade Your Metadata”.
5. “Set Up the SAS/CONNECT Spawner (Windows only)”.
6. “Reestablish Existing Schedule Flows”.

Stop the Metadata Server

The SAS Configuration Wizard automatically starts the metadata server. To make sure that there are no file contention issues, stop the metadata server before you copy any files into the new configuration directory.

Copy Files from the Original Configuration Directory

In the typical use of the configuration, you will have created and modified files in your original configuration directory. For example, you might have added SAS system options to the configuration file *path-to-config-dir\Lev1\SASMain\sasv9.cfg*. You need to determine which of these new or modified files you should copy to the new configuration. Also, you need to move your original metadata repository to the new configuration. Use the following directions:

- If you changed a host name, pathnames, or port numbers that are associated with the configuration, you need to ensure that the new configuration directory contains the correct information.
- If you added tuning options or other options to your original configuration, you should add those options to (or maintain those options in) the new configuration.
- You must always copy the SAS Metadata Server files to the new configuration. These files are contained in the **MetadataServer/reposmgr** and **MetadataServer/MetadataRepositories** directories. You should place these files in the same location in the new configuration directory.

Start the Metadata Server

You need to restart the metadata server before continuing this procedure.

Upgrade Your Metadata

Using SAS Management Console, upgrade your existing metadata repositories:

- Log on to SAS Management Console as an unrestricted user.
- Expand the Metadata Manager node in the SAS Management Console tree.
- Right-click the Active Server icon and select **Upgrade Metadata** from the pop-up menu.

All non-project repositories on the active server will be upgraded.

Note: If you have changed a host name, pathnames, or port numbers that are associated with the configuration, you will need to ensure that the metadata definitions contain the new information. To validate host names and port numbers, use the Server Manager plug-in to SAS Management Console: select the physical server definition; then, examine the properties of the connection shown in the right-hand view of the console. To verify pathnames, use the same plug-in to edit the properties of the physical server definition.

Note: If you are working on a Windows machine, have registered local users (*host-name\user-ID*) in the metadata in your original configuration, and are running the new configuration on a different machine, you must modify the host-name qualifier on each user ID. You do this using the User Manager plug-in to SAS Management Console. Edit users and groups as appropriate, changing the user IDs on the **Logins** tab.

Set Up the SAS/CONNECT® Spawner (Windows only)

If you plan to run a SAS/CONNECT server on this machine, you should run the script that was supplied by SAS that sets up the SAS/CONNECT spawner to run as a service. You can find this script in the directory *path-to-config-dir\Lev1\SASMain\ConnectServer*. It is called **InstallConnectServer.bat**.

Reestablish Existing Schedule Flows

When you upgrade your metadata, existing scheduled flows are preserved. Although flows that you create in 9.1.3 are represented slightly differently in the metadata, your 9.1[.2] flows will continue to work. The 9.1.3 Schedule Manager supports both types of flows. All you need to do is to reschedule the previously scheduled jobs in the Schedule Manager.

Note: If you have not installed your 9.1.3 scheduling software yet, wait to perform this step until after you have installed that software.

For each flow that you want to schedule, perform the following steps:

1. Right-click the flow and select **Schedule Flow** from the pop-up menu.
2. Click **Yes** in the Reschedule confirmation dialog box.
3. Choose the trigger to start the flow, and click **OK**. This will schedule the flow with Platform Computing's JobScheduler.

Server Machine, No Metadata Server

Follow the steps in this section on all machines that host SAS servers, but do not host the metadata server.

Reapply Customizations from the Original Configuration Directory

In the typical use of the configuration, you will have created and modified files in your original configuration directory. For example, you might have added SAS system options to the configuration file *path-to-config-dir\Lev1\SASMain\sasv9.cfg*. You need to determine which of these new or modified files you should copy to the new configuration. Use the following rules to make this decision:

- If you changed a host name, pathnames, or port numbers that are associated with the configuration, you need to ensure that the new configuration directory contains the correct information.
- If you added any tuning or other options to your original configuration, you should add those options to (or maintain those options in) the new configuration.

Set Up the SAS/CONNECT Spawner (Windows only)

If you plan to run a SAS/CONNECT server on this machine, you should run the script that was supplied by SAS that sets up the SAS/CONNECT spawner to run as a service. You can find this script in the directory *path-to-config-dir\Lev1\SASMain\ConnectServer*. It is called **InstallConnectServer.bat**.

Start Your Servers

You can now start the servers in your configuration. For details on how to perform this step, see the **instructions.html** file from your 9.1[.2] installation.

Middle-Tier Machine

You should perform the steps that are listed in the following sections on a machine where a middle tier is configured (for example, where the SAS Web Infrastructure Kit is installed). Note that a couple of these steps apply only when you are upgrading from 9.1 to 9.1.3 (not from 9.1.2 to 9.1.3).

1. "Reapply Customizations from the Original Configuration Directory".
2. "Prepare to Reapply Customizations to Web Applications".
3. "Upgrade User and Group Definitions (9.1 to 9.1.3 only)".
4. "Define the SAS Foundation Services in the Metadata".

5. "Update the SAS Web Infrastructure Kit Metadata".
6. "Copy Custom Portlets to the Installation Directory".
7. "Migrate Your WebDAV Data to a 9.1.3 Test System (SAS Information Delivery Portal)".
8. "Migrate Your WebDAV Data to a 9.1.3 Test System (SAS Web Report Studio)".
9. "Migrate Your WebDAV Data in the 9.1.3 Production System (SAS Information Delivery Portal)".
10. "Migrate Your WebDAV Data in the 9.1.3 Production System (SAS Web Report Studio)".
11. "Start the SAS Services Application".
12. "Deploy Your Web Applications".

Note: If your metadata server is configured on this machine, you can skip Step 1. You should have performed that step earlier.

Reapply Customizations from the Original Configuration Directory

In the typical use of the configuration, you will have created and modified files in your original configuration directory. You need to determine which of these new or modified files you should copy to the new configuration. Use the following rules to make this decision:

- If you changed a host name, pathnames, or port numbers that are associated with the configuration, you need to ensure that the new configuration directory contains the correct information.
- If you added any tuning or other options to your original configuration, you should add those options to (or maintain those options in) the new configuration.

Prepare to Reapply Customizations to Web Applications

If you have customized any files that are part of a SAS Web application, such as SAS Web Report Studio or SAS Information Delivery Portal, you must back up the files that you have modified. You should restore these files after you redeploy your Web applications as described in "Deploy Your Web Applications".

Upgrade User and Group Definitions (9.1 to 9.1.3 only)

In SAS Management Console, add the SAS Web Administrator (**saswbadm**) to the SAS System Services group.

1. Select the User Manager plug-in to SAS Management Console. You will see a list of groups and users on the right side of the GUI.
2. Right-click the SAS System Services group, and select **Properties** from the pop-up menu. A properties dialog box appears.
3. Select the **Members** tab.
4. Move the SAS Web Administrator from the **Available Members** list to the **Current Members** list.
5. Click **OK** to save this group information.

Define the SAS Foundation Services in the Metadata

You need to load the 9.1.3 SAS Foundation Services into the metadata before anyone uses the SAS 9.1.3 Web applications. To do this, you use the Foundation Services Manager plug-in to SAS Management Console.

1. Right-click the Foundation Services Manager, and select **Import Service Deployment** from the pop-up menu. An Import Service Deployment dialog box appears.
2. Remove any existing service-deployment import files by selecting them and clicking the **Remove** button.

3. Click **Add** in this dialog box. A file browser (an Open dialog box) appears.
4. Use the file browser to display the contents of the directory

path-to-config-dir\Lev1\web\Deployments\Portal

5. Select the following files and click **Open**.

- **sas_services_idp_remote_omr.xml**
- **sas_services_idp_local_omr.xml**

The names of these files will be displayed in the Import Services Deployment dialog box.

6. In the same way, add this file to the list:

path-to-config-dir\Lev1\web\Deployments\WebReportStudio\
servername_sas_pfs_queryandreporting.xml

7. Click **OK** in the Import Service Deployment dialog box.

Note: If you have installed the SAS BI Web Services for Java, you should also use the Foundation Services Manager to import the file *path-to-config-dir*\Lev1\web\Deployments\WebServices\sas_services_websvc_local_omr.xml.

Update the SAS Web Infrastructure Kit Metadata

You must also update the metadata for the SAS Web Infrastructure Kit before anyone uses the SAS 9.1.3 Web applications. In the directory *SAS-install-dir*\Web\Portal2.0.1\OMR, you will find a set of SAS programs. You must run a subset of these programs—in the order indicated in the following list—and check the log for any errors. There should be no errors.

If you are upgrading a 9.1.2 system to 9.1.3, run the following programs:

1. **Remove912PreferenceDefs.sas**
2. **LoadDefaultPreferences.sas**

If you are upgrading a 9.1 system to 9.1.3, run the following programs:

1. **LoadDefaultPreferences.sas**
2. **LoadPreferencesConnection.sas**
3. **LoadThemeConnection.sas**

On Windows systems, you can run these programs from the Windows Explorer. Right-click the SAS file, and select **Batch Submit with SAS 9.1** from the pop-up menu. After executing each SAS program, check the corresponding log file. (This file will have the same name as the program, but will end with a **.log** extension.) Open each log file and search for the string “ERROR:”. You should only find program statements that contain this string, not log messages.

For more details about this step, see “Install Metadata” in the SAS Web Infrastructure Kit README file, *wik_readme.html* (sometimes called the *SAS Web Infrastructure Kit Deployment Notes*).

Copy Custom Portlets to the Installation Directory

Portlets are mini-applications that run inside the framework that is provided by the SAS Web Infrastructure Kit. If you have created any custom portlets, you must perform one of the following tasks:

- If you are building a test system, copy the portlets from the directory *SAS-install-dir\WebPortal2.0.1\DeployedPortlets* on your 9.1[.2] system to the same directory on your 9.1.3 system.
- If you are replacing your production system, copy the custom portlets from their back-up location or your test system to your 9.1.3 production system.

Note: You do not need to copy portlets that were supplied with your SAS software. You need to copy only portlets that you developed yourself.

Migrate Your WebDAV Data to a 9.1.3 Test System (SAS Information Delivery Portal)

Important Note: Follow the instructions in this section **only** if both of the following are true:

- You are moving your 9.1[.2] WebDAV data to a 9.1.3 test system.
- You are using SAS® Information Delivery Portal with its WebDAV features enabled.

If you are also using SAS® Web Report Studio, see “Migrate Your WebDAV Data to a 9.1.3 Test System (SAS Web Report Studio)” as well.

To move your 9.1[.2] WebDAV data to a 9.1.3 test system, follow these instructions:

1. Install Xyθος WebFile Server on the middle-tier host in your test system.
 - a. Create new databases or database schemas to hold your current WebDAV data. Using your database vendor’s documentation, create one database or schema to hold your current WFS Global Schema, and create a database or schema for each of your existing Document Stores.
 - b. Install Xyθος WFS and specify the new database locations during installation.
2. Copy your existing WebDAV content to the new repository.
 - a. Export the data from your 9.1[.2] Global Schema database, and import that data into the Global Schema database on your test system. Then, export the data from each 9.1[.2] Document Store, and import the data into the Document Stores that you just created. (For detailed information about how to import and export data, refer to your database vendor’s documentation.)
 - b. If external storage is enabled in your 9.1[.2] Xyθος WFS setup, copy the existing external storage files into the test copy of Xyθος WFS.
3. On the test system, update the JDBC connection URL that is used by Xyθος WFS so that it points to the new Xyθος Global Schema.
 - a. Edit the **xyθος.properties** file in your new installation, and set the **BaseJDBCConnectionURL** property to the connection string for the copied Xyθος Global Schema.
 - b. Start the new copy of WFS.
 - c. From the Xyθος Administration Pages, for each document store, update the parameters **Storage Location**, **JDBC Connection URL**, **DB User Name**, and **DB Password**. (To get to the page for a document store, select **SERVER ADMINISTRATION => Servers => Document Stores**.)
4. Update the metadata definition of the connection for your HTTP DAV Server. Using the Server Manager plug-in to SAS Management Console, set the **Host Name** to the name of the middle-tier host in your test system.

Migrate Your WebDAV Data to a 9.1.3 Test System (SAS Web Report Studio)

Important Note: Follow the instructions in this section **only** if both of the following are true:

- You are moving your 9.1[.2] WebDAV data to a 9.1.3 test system.
- You are using SAS Web Report Studio.

If you are also using SAS Information Delivery Portal and that application's WebDAV capabilities are enabled, you should already have followed the instructions in "Migrate Your WebDAV Data to a 9.1.3 Test System (SAS Information Delivery Portal)".

If you are using Xythos WebFile Server as your WebDAV server, migrate your WebDAV data to your test system using the instructions in "Migrate Your WebDAV Data to a 9.1.3 Test System (SAS Information Delivery Portal)"—if you have not already performed those tasks. Then, use SAS Management Console to update the properties of your BIP Tree:

1. Expand the Business Report Manager node.
2. Right-click the BIP Tree icon and select **Properties** from the pop-menu that appears. A BIP Tree Properties dialog appears.
3. In this dialog box, update the value of the **Content Server** field. Also, update the SAS Web Administrator's password, if necessary. Then, click **OK**.

If you are using the Apache HTTP Server as your WebDAV server, use the following directions to move your WebDAV content to your test system:

1. On your test system, create the directory structure **/sasdav/wrs** inside the **htdocs** directory in your Apache installation.
2. Move the contents of **/sasdav** on your 9.1[.2] system to **/sasdav/wrs** on the test system. You can use any program that enables you to move files for this task: Windows Explorer, FTP, and so on.
3. On the test system, update the metadata definitions of your HTTP Server and BIP Tree.
 - Use the Server Manager plug-in to SAS Management Console to add a new **Base Path (/sasdav/wrs)** to the HTTP Server and to update the **Host Name** on the HTTP Server's connection.
 - Use the Business Report Manager plug-in to edit the properties of the BIP Tree as necessary. You will have to at least change the **Content Server** and the **Content Base Path**; you might also need to change the **Content Server Authentication** information.

Migrate Your WebDAV Data in the 9.1.3 Production System (SAS Information Delivery Portal)

Important Note: Follow the instructions in this section only if both of the following are true:

- You are upgrading your 9.1[.2] WebDAV repository in place so that it can be part of a 9.1.3 production system.
- You are using SAS Information Delivery Portal with its WebDAV features enabled.

If you are also using SAS Web Report Studio, see "Migrate Your WebDAV Data in the 9.1.3 Production System (SAS Web Report Studio)" as well.

When you upgrade your 9.1[.2] production system to 9.1.3, you should move your SAS Information Delivery Portal WebDAV data to a new location on your Xythos WebFile Server. You need to change your base path root from **/** to **/sasdav** and then move your WebDAV data to the new location. This change will result in better performance and will make the system consistent with any newly installed 9.1.3 systems. To make the change, perform the following steps:

1. Make sure that you have the latest User Management code installed in your Xythos WFS installation area. You can obtain the latest JAR files and scripts from the 9.1.3 Xythos WFS installation CD. Unzip **saswfs.zip** into *Xythos-install-dir\wfs-4.0.48*.
2. Run the **WFSInstaller.bat** script located in *Xythos-install-dir\wfs-4.0.48*. In the installation screen presented, fill in the appropriate values for each field. You can look at your existing *Xythos-install-dir\wfs-4.0.48\saswfs.properties* file to see how the values were set during the previous installation. In the **Enter the path to the user area** field, enter **/sasdav**.

Note: For new installations, SAS recommends defining a user area **/sasdav/Users**. SAS does not recommend **/sasdav/Users** for an upgrade, because you will lose access to content in your personal repository, such as alerts.

Note: The base path root specified in the Xythos WebFile Server installation must match the value specified during the SAS Web Infrastructure Kit installation.

3. Run the **WFSInstaller2.bat** script that is located in the same directory. This script will create a **/sasdav** top-level directory on the Xythos WFS. This directory is referred to as the base path root. If you set the user area to **/sasdav/Users**, the script will also create a **/sasdav/Users** directory to store each user's personal content. If you did not set the user area this way, each user's personal content will be stored in **/sasdav**.
4. Stop and restart the Xythos WFS so that the new settings take effect.
5. When you unpacked the file **saswfs.zip** in Step 1, the migration utilities **MovePersons** and **MoveResources** were placed in the directory **wfs-4.0,48\utils**. The usage information for the two utilities is as follows:

```

-----
MovePersons (Version 1.0.001)
-----
Usage: MovePersons [/v] dir1 dir2
eg. MovePersons / /sasdav/Users
where
    dir1 is the source directory for person entries
    dir2 is the target directory
options
    /v verify operation, but do not actually do the move

```

```

-----
MoveResources (Version 1.0.001)
-----
Usage: MoveResources [/v] dir1 regex dir2
eg. MoveResources /v / ".*" /sasdav
where
    dir1 is the source directory for person entries
    dir2 is the target directory
options
    /v verify operation, but do not actually do the move

```

6. In both of these scripts, make sure that the **XYTHOS_HOME** and **JDBC_DRIVER** environment variables are set correctly. For example, you might need to set their values like this:

```

set XYTHOS_HOME=c:\xythos
set JDBC_DRIVER=c:\cygwin\usr\share\postgresql\java\postgresql.jar

```

It is also a good idea to define the environment variable **JAVA_HOME** at the top of both scripts to make sure that you know which version of the JDK you are using:

```

set JAVA_HOME=c:\j2sdk1.4.2

```

7. Migrate user folders from / to **/sasdav** using the **MovePersons.cmd** script. For example, you might use the command:

```
C:\xythos\wfs-4.0.48\utils>MovePersons.cmd / /sasdav
```

If you set the user area to **/sasdav/Users** in Step 2, then the second argument to this script should be **/sasdav/Users**.

8. Migrate other top level SAS content folders using the **MoveResources.cmd** script. For instance, the example below shows how you might move a **/Sales** folder containing Microsoft Office documents, a **/sas/publish** folder with publication/ subscription content, and a **/ReportStudio** folder containing reports:

```
C:\xythos\wfs-4.0.48\utils>MoveResources / "Sales" /sasdav
C:\xythos\wfs-4.0.48\utils>MoveResources / "sas" /sasdav
C:\xythos\wfs-4.0.48\utils>MoveResources / "ReportStudio" /sasdav
```

9. If you have defined your WebDAV server in your metadata, bring up SAS Management Console, and go to the Server Manager plug-in. Right-click the icon representing your WebDAV server and select **Properties** from the pop-up menu that appears. In the Properties dialog box, select the **Options** tab. In the **Base Path(s)** list, change / to **/sasdav**.
10. If you have defined channels with a WebDAV persistent store in the metadata, bring up SAS Management Console, and go to the Publishing Framework plug-in. Expand the tree to list the channels. Right-click each channel that uses WebDAV for a persistent store, and select **Properties** from the pop-up menu that appears. In the Properties dialog box, select the **General** tab. In the **Content Base Path** drop-down list, change / to **/sasdav**.
11. Make sure that the \$DAV_BASE\$ name/value pair located in the file *SAS-install-dir\WebPortal2.0.1\PortalConfigure\install.properties* is set to **/sasdav**. This value is the DAV base bath root used to configure the Web Infrastructure Kit (WIK). The base path root is used in the WIK's local services deployment definition: there is a repository definition entry for the DAV server in the information services configuration.
12. Run the script **configure_wik**. This script is located in the directory *SAS-install-dir\WebPortal2.0.1*.
13. If the services deployment definitions are loaded in your metadata repository, reload the service definitions to make sure that the DAV repository definition entry has the correct base path.

Migrate Your WebDAV Data in the 9.1.3 Production System (SAS Web Report Studio)

Important Note: Follow the instructions in this section only if both of the following are true:

- You are upgrading your 9.1[.2] WebDAV repository in place so that it can be part of a 9.1.3 production system.
- You are using SAS Web Report Studio.

If you are also using SAS Information Delivery Portal and that application's WebDAV capabilities are enabled, you should already have followed the instructions in "Migrate Your WebDAV Data in the 9.1.3 Production System (SAS Information Delivery Portal)".

If you are replacing your 9.1[.2] production system, you should follow the appropriate directions below—depending on whether you are using the Xythos WebFile Server or the Apache HTTP Server as a WebDAV server. In either case, you should make your existing WebDAV content available at the content base path **/sasdav/wrs** instead of (or in addition to) **/dav/sas**. This section explains how to migrate your content for each of these servers.

If you are using the Xythos WebFile Server as your WebDAV server, use the following procedure:

1. Use the Xythos WFS administration console to create the folder structure **/sasdav/wrs**.
2. Use the Xythos WFS administration console to grant the SAS Web Administrator (**saswbadm**) full access to the **wrs** folder and to deny access to this folder to other users.
3. Copy your existing WebDAV content from **/dav/sas** to **/sasdav/wrs**.
4. In SAS Management Console, use the Server Manager plug-in to change the properties for your WebDAV server (HTTP DAV Server). Right-click the icon that represents this server and select **Properties** from the pop-up menu. A properties dialog box appears. On the **Options** tab, create a new base path: **/sasdav/wrs**.
5. In SAS Management Console, use the Business Report Manager plug-in to update the properties of the BIP Tree. Expand the Business Report Manager. Then right-click the BIP Tree icon and select **Properties** in the pop-up menu that appears. A properties dialog box appears. Set the **Content Base Path** to **/sasdav/wrs**, and enter the user ID and password for the SAS Web Administrator in the **Content Server Authentication** area.

If you are using the Apache HTTP Server as your WebDAV server, use the following procedure:

1. Edit the **httpd.conf** configuration file to create an alias for the content base path. This way, you do not have to actually copy your WebDAV content to a new location. When you first configured your system, you should have added an element like this to this file:

```
<Directory "C:\Program Files\Apache Group\Apache2\htdocs\dav\sas">  
SetEnv redirect-carefully 1  
Dav On  
DavDepthInfinity On  
Options None  
AllowOverride None  
</Directory>
```

Add the following line just before this element:

```
Alias /sasdav/wrs "C:\Program Files\Apache Group\Apache2\htdocs\dav\sas"
```

Then, save the file.

2. In SAS Management Console, use the Server Manager plug-in to change the properties for your WebDAV server (HTTP DAV Server). Right-click the icon that represents this server and select **Properties** from the pop-up menu. A properties dialog box appears. On the **Options** tab, create a new base path: **/sasdav/wrs**.
3. In SAS Management Console, use the Business Report Manager plug-in to update the properties of the BIP Tree. Expand the Business Report Manager. Then right-click the BIP Tree icon and select **Properties** in the pop-up menu that appears. A properties dialog box appears. Set the **Content Base Path** to **/sasdav/wrs**, and enter the user ID and password for the SAS Web Administrator in the **Content Server Authentication** area.

Start the SAS Services Application

You should now start the SAS Services application. For more information about how to perform this step, see the directions in your initial configuration instructions, **instructions.html**.

Deploy Your Web Applications

Your Web applications will have been upgraded. Redeploy these new versions to your Web server.

1. If necessary, uninstall the current version of each SAS Web application. If you are using Tomcat as your Web server, delete the directory structure for a Web application from the **webapps** directory. If you are using the BEA WebLogic server as your Web server:
 - Use the WebLogic Server administration console to delete an application. (To see the currently deployed Web applications, expand the Deployments tree node, and select the Web Applications node. In the resulting list of Web applications, select the Delete icon for the appropriate application.)
 - Remove the directory structure for the Web application from the **webapps** directory.
2. To deploy the new Web applications, follow the directions in the section “Deploy Your Web Applications” in your configuration instructions, **instructions.html**.

Note: For more detailed information about deploying your Web applications, see the section “Getting More Information” in **instructions.html**.
3. If you are using Tomcat as your servlet container, start Tomcat. For directions on how to do this, see “Start Your Tomcat Server” in **instructions.html**.

Upgrading a SAS 9.1 or 9.1.2 z/OS System to a SAS 9.1.3 System

The following two sections explain how to create a SAS z/OS business intelligence installation that you can swap into a functioning SAS 9.1 or SAS 9.1.2 business intelligence installation. Be certain to follow the steps in order.

Installing and Configuring the SAS 9.1.3 Software

Follow these instructions to install and configure a 9.1.3 system that you can test before you put it into production. The documentation referenced below is located on the Install Center (<http://support.sas.com/installcenter>), in the Installation Kit, or on the **Documentation for Installing and Configuring SAS CD**.

1. Install SAS 9.1.3 Foundation for z/OS using the “Action A” instructions for installing a completely new SAS Foundation for z/OS. You can use the SAS Installation Wizard for z/OS for this task. The high level prefix that you use for this installation is *not* critical.

Note: The “Action A” instructions are located in the **Installation Instructions for SAS 9.1.3 Foundation for z/OS**.

2. Perform all of the necessary post-installation customization tasks for the new SAS 9.1.3 Foundation for z/OS. These customizations are described in appendices in the **Configuration Guide--SAS 9.1.3 Foundation for z/OS**, and should mirror the customizations that you performed when installing the SAS 9.1 or SAS 9.1.2 Foundation for z/OS.
3. In the control data set used for installing the new SAS 9.1.3 Foundation for z/OS (hereafter referred to as the **CNTLDSN**), open an editor on the member **UGTARGET**.

Edit the following line:

```
UGPFX=SAS.V91.PROD.PFX <==SUPPLY YOUR PRODUCTION SAS PREFIX
```

Substitute the high-level prefix of your production or existing SAS 9.1 or SAS 9.1.2 Foundation for z/OS system for **SAS.V91.PROD.PFX**.

Then save the member.

4. Open the editor on **CNTLDSN(MAKEUPG)**. Locate the following JCL near the beginning of the job:

```
//INSTEDT1 PROC CNTLDSN='your_ctrl_data_set',  
// SASPROC='SAS' <==== << SUPPLY >>  
// SASEDTP='SASEDITP', <==== << VERIFY >>  
// SYSOUT='*', <==== << VERIFY >>  
// DISKUNI='DISK' <==== << VERIFY >>
```

Then, follow these steps:

- a. In the line with **SASPROC='SAS'**, substitute the procedure name of a working SAS 9.1, 9.1.2, or 9.1.3 PROC.
 - b. Do not change **SASEDITP=parm** unless directed to do so by SAS Technical Support.
 - c. Verify the **SYSOUT=** and **DISKUNI=parms** DD statements, which should have been set correctly from the main install.
 - d. Save the edit.
5. Submit **CNTLDSN(MAKEUPG)** for execution. This will create four utilities to be used later. The names will contain the *actual* TS level identifiers of the production (old) and newly installed systems, obtained by analyzing the executables library of the production and new systems. These two TS level identifiers will also be used in the new data set names created by running the utilities.

In the section “Replacing Your Production System”, “TSpMp” (your production or old system) and “TSnMn” (your newly installed system) may have actual values of TS1M0 and TS1M3 as one of a number of possible TS level combinations. Substitute your actual TS level values for **TSpMp** and **TSnMn**.

6. After the new system has been deemed production quality, and during system down time, perform the following steps:
 - a. Stop the version 9.1 or 9.1.2 servers.
 - b. Copy the SAS 9.1 or 9.1.2 configuration directory to the SAS 9.1.3 configuration directory. You can do this by running the following command from the UNIX System Services shell:

```
cp -R 9.1_config_dir 9.1.3_config_dir
```

- c. Remove old log files from the 9.1.3 configuration directory. Use a command similar to this one:

```
rm 9.1.3_config_dir/Lev1/SASMain/*/logs/*
```

- d. Edit the COPYIA job with the location of the 9.1.3 configuration directory. (Supply the value for the CONFIG_DIR variable.) The COPYIA job is located in the *sas_v913_installed_prefix.W0.SRVCNTL* data set. Run the COPYIA job, and verify a successful completion.
- e. Copy **configuration.properties** from your 9.1 or 9.1.2 configuration directory to your 9.1.3 configuration directory. From the USS shell, issue the command:

```
cp 9.1_config_dir/Utilities/zOS_config/configuration.properties  
9.1.3_config_dir/Utilities/zOS_config/configuration.properties
```

- f. Change directories so that you are in the zOS_config directory inside the 9.1.3 configuration directory. To get there, use the USS shell command:

```
cd 9.1.3_config_dir/Utilities/zOS_config
```

- g. Edit the 9.1.3 version of **configuration.properties**, supplying new values for the following properties:
- \$CONFIG_DIR\$ - Point to the 9.1.3 configuration directory.
 - \$APPSERVER_DIR\$ - Point to the new application-server directory, for example, *9.1.3_config_dir/Lev1/SASMain*.
- h. You need to change only the following values if your site wants to run the 9.1.3 servers in parallel with the 9.1 or 9.1.2 servers during a testing period. This is the recommended approach. If your site wants to run the 9.1.3 servers right out of the box, just as they were configured in 9.1 or 9.1.2, then you do not need to change any of the following values:
- \$OMAPORT\$ - Enter a new port number.
 - \$OMA_STCNAME\$ - Enter a new started task name (different from the 9.1 or 9.1.2 name).
 - \$OMA_CFGNAME\$ - Enter a new configuration file name (same as the started task name).
 - \$OMA_TKENVM\$ - Enter the new tk environment file name (same as the started task name).
 - \$SPAWNER_OPERATOR_PORT\$ - Enter a new port number.
 - \$SPAWNER_LOADBALANCING_PORT\$ - Enter a new port number.
 - \$IOM_PORT\$ - Enter a new port number.
 - \$SPAWNER_STCNAME\$ - Enter a new started task name.
 - \$SPAWNER_PRMNAME\$ - Enter a new parm name.
 - \$STP_PORT\$ - Enter a new port number.
 - \$STP_PORT1\$ - Enter a new port number.
 - \$STP_PORT2\$ - Enter a new port number.
 - \$STP_PORT3\$ - Enter a new port number.
 - \$OLA_PORT\$ - Enter a new port number.
 - \$OLA_STCNAME\$ - Enter a new started task name.
 - \$OLA_CFGNAME\$ - Enter a new configuration file name.
 - \$OLA_TKENVM\$ - Enter a new tk environment file name.
 - \$CONNECT_PORT\$ - Enter a new port number.
 - \$SHAREPORT\$ - Enter a new port number.
 - \$SHR_STCNAME\$ - Enter a new started task name.
 - \$SHR_CFGNAME\$ - Enter a new configuration file name.
 - \$SHR_TKENVM\$ - Enter a new tk environment file name.
 - \$CNT_STCNAME\$ - Enter a new started task name.
 - \$CNT_PRMNAME\$ - Enter a new parm file name.
- i. Run the **deploy_IA.sh** script.
- ```
deploy_IA.sh -p configuration.properties
```
- If you are asked whether you want to overwrite the environment, answer **Yes**.
- j. Copy the new started task names to your site's started task library.
- k. Start the metadata server.

- I. Using SAS Management Console, upgrade your existing metadata repositories.
  - Expand the Metadata Manager plug-in to SAS Management Console.
  - Right-click the Active Server icon and select **Upgrade Metadata** from the pop-up menu.
- m. Using SAS Management Console, update the metadata for the 9.1.3 system (using the 9.1.3 **instructions.html** as a guide). Change:
  - the Launch Command for the workspace server.
  - the Launch Command for the stored process server.
  - the Launch Command for the SAS/CONNECT server.
  - all the port numbers listed previously.
- n. Start the remaining servers.
- o. Test all of the servers.

## Replacing Your Production System

In the following steps, you will rename your production and newly installed SAS system data sets in order to facilitate the changeover between your existing production SAS environment and the newly installed SAS system. You will accomplish this by running the **RNMTSpMp** and **RNMTSnMn** utilities, which will rename the existing SAS datasets using the following guidelines:

- **SAS.V91.PROD.PFX.\*** becomes **SAS.V91.PROD.PFX.TSpMp.XXX**
- **SAS.V913.PFX.\*** becomes **SAS.V91.PROD.PFX.TSnMn.XXX**

Alias names will be created for the originally installed data set names, and they will now point to the recently renamed data set names.

**CAUTION: Note that the alias names are alternate names for data sets that are defined in the catalog.** RACF does not allow alias names because it uses the RACF database, not the catalog, for its processing. If you have existing RACF profiles for your SAS installation, you might need to adjust these profiles based on the new data set names.

**CAUTION: If your installation currently uses, or has future plans to run, a SAS/CONNECT spawner or object spawner, note that the SAS executable library and the SAS/C transient library must be put under RACF program control.** Because RACF does not support alias names, you must use the renamed, fully qualified data set names in the program control table.

**CAUTION: After the RNMTSpMp utility is executed, the SAS/CONNECT and object spawners will not function until the SAS.V91.PROD.PFX.TSpMp.DLR (the renamed SAS/C transient library) and SAS.V91.PROD.PFX.TSpMp.DLD (the renamed SAS executable library) have been added to the program control table.**

1. During system downtime, submit the utility **CNTLDSN(RNMTSpMp)**. This utility will rename the production system data sets and create aliases from the existing names to the new names. If you need to run this utility outside of system downtime, you must follow a locally appropriate procedure to ensure that data sets are not in use or enqueued, which will cause the process to fail.
2. Add the **SAS.V91.PROD.PFX.TSpMp.DLR** and **SAS.V91.PROD.PFX.TSpMp.DLD** libraries to the program control table, if your existing production SAS installation uses a SAS/CONNECT spawner or object spawner.
3. Submit the utility **CNTLDSN(RNMTSnMn)**. This utility will rename the new system data sets and create aliases from the existing names to the new names.

4. Add the **SAS.V91.PROD.PFX.TSnMn.DLR** and **SAS.V91.PROD.PFX.TSnMn.DLD** libraries to the program control table, if your existing production SAS installation uses a SAS/CONNECT spawner or object spawner.

**Note:** The TSxxx portion of these names is taken from the TS level that is obtained from the installed systems and will vary depending on the version of the installed systems.

You are now ready to perform a swap.

5. During system downtime, or during a testing period where access to and enqueues upon the SAS System can be controlled, submit the utility **CNTLDSN(USETSnMn)**, which will cause the production-named aliases to point to the new SAS System of that TS level. Note that once you have submitted the **USETSnMn** utility, the 9.1.3 SAS System will be the production environment. Therefore, only the BI server started tasks that were created in Step 6j are valid for use. The 9.1 or 9.1.2 BI server started tasks that were previously defined in your started tasks library will not be valid unless you change the system back to 9.1 or 9.1.2 by running the **CNTLDSN(USETSpMp)** utility.
6. Perform tests as needed or scheduled to verify that the new production system is functioning properly.
7. You can perform an emergency restoration of the previous system by submitting the utility **CNTLDSN(USETSpMp)**.

SAS and all other SAS Institute Inc. product or service names are registered trademarks or trademarks of SAS Institute Inc. in the USA and other countries. ® indicates USA registration. Other brand and product names are trademarks of their respective companies.

Copyright © 2007, SAS Institute Inc. All rights reserved.